

## Instructions

Extend Card (RS485 Data)

Model No. **WJ-PB85R08**

Before attempting to connect or install this product, please read these instructions carefully and save this manual for future use.

### Caution

Hold this board only by its edges. Otherwise components on the board may be damaged by static electricity.

## ■ Preface

The WJ-PB85R08 RS485 Data Board is an optional board for exchange of control data between the Camera Control Cage (MXCONT) and the camera site.

## ■ Appearance

### ① Data Connectors (TA/TB/RA/RB/G 1 - 8)

These connectors are used to exchange control data between the camera site equipment. For connection, use a data grade shielded 4-wire twisted pair cable suitable for RS-485 communication.

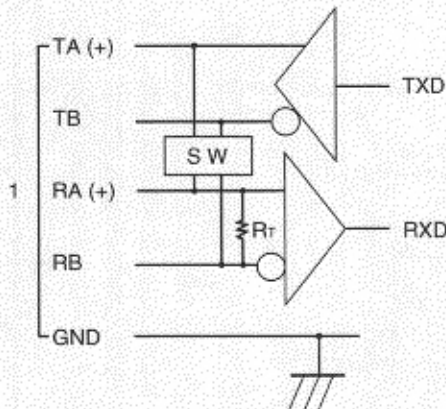

R<sub>t</sub>: Termination Resistor  
SW: Selection Switch, Full Duplex/ Half Duplex  
GND: Ground: Connected to each channel and common ground.

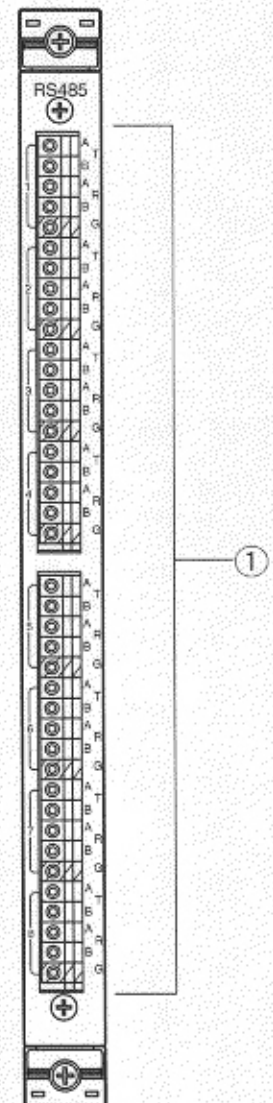

# Board Setting

Before installing this board, the following settings should be made by qualified service personnel or system installers.

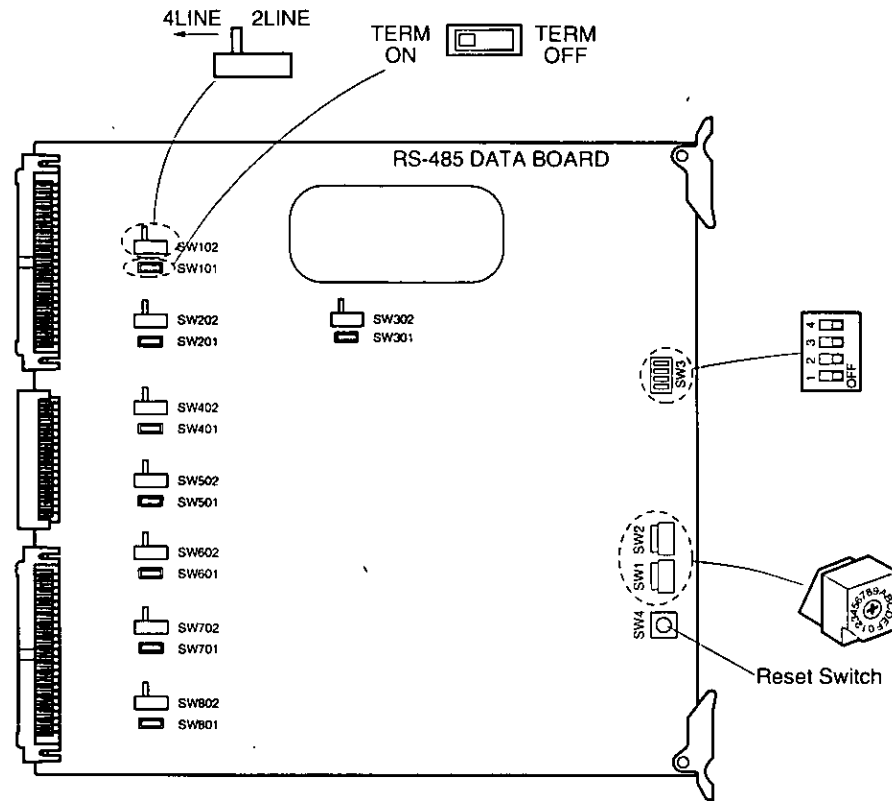

- Set switches (SW1 and SW2) on the board to designate the RS-485 Data board number as shown in the following table. The factory default setting is Board Number 1 (00).

Board No.	Data I/O	SW Positions	
		SW2	SW1
1	1 - 8	0	0
2	9 - 16	0	1
3	17 - 24	0	2
4	25 - 32	0	3
5	33 - 40	0	4
6	41 - 48	0	5
7	49 - 56	0	6
8	57 - 64	0	7
9	65 - 72	0	8
10	73 - 80	0	9
11	81 - 88	0	A
12	89 - 96	0	B
13	97 - 104	0	C
14	105 - 112	0	D
15	113 - 120	0	E
16	121 - 128	0	F

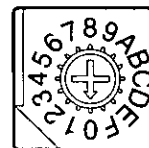

2. Set switches (SW101, SW201, SW301, SW401, SW501, SW601, SW701, and SW801) on the board to choose either data termination ON or OFF as shown below.  
The factory default settings are TERM ON.



3. Set switches (SW102, SW202, SW302, SW402, SW502, SW602, SW702, and SW802) on the board to choose either Full Duplex (4 LINE) or Half Duplex (2 LINE) communication lines as shown below.  
The factory default settings are Full Duplex (4 LINE).

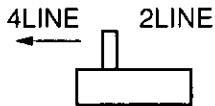

4. Confirm that switches (SW3) on the board are set to the OFF position as shown below.

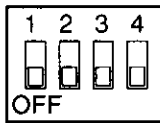

DIP	ON	OFF
1	One way mode	Handshake mode
2	No retry mode	3 retries mode
3	Reserved	Reserved
4	Reserved	Reserved

## Installation

The following installation should be made by qualified service personnel or system installers.

### Installing Additional Extension Boards

1. Remove the screws from the rear panel(s) of the WJ-SX850 Matrix Switcher Card Cage.

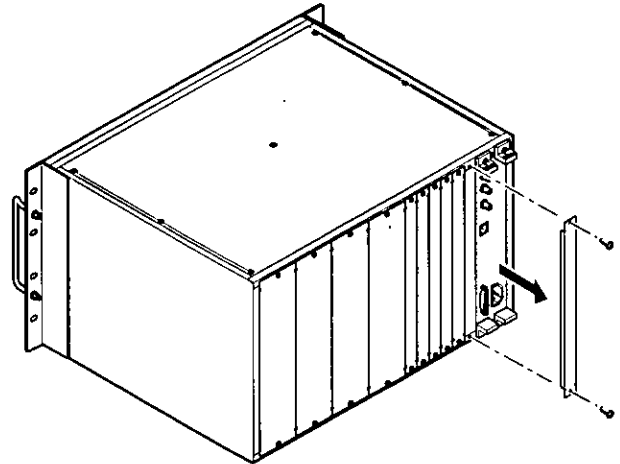

2. Remove the rear panel(s).

3. Remove the front panel of the cage by removing the two screws on the panel shown below.

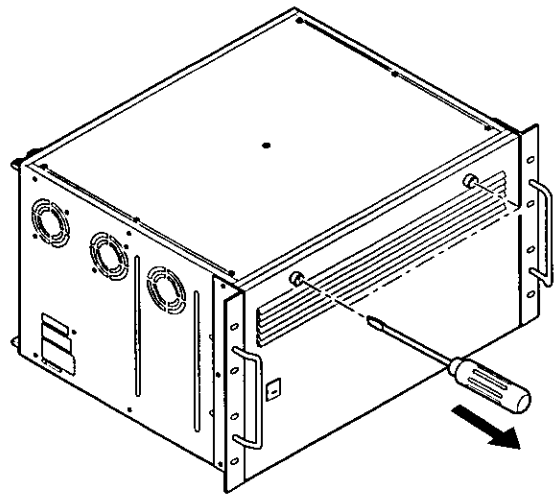

4. Place the Boards into the specified positions in the front or rear of the Cage by sliding them along the board guides as shown below.

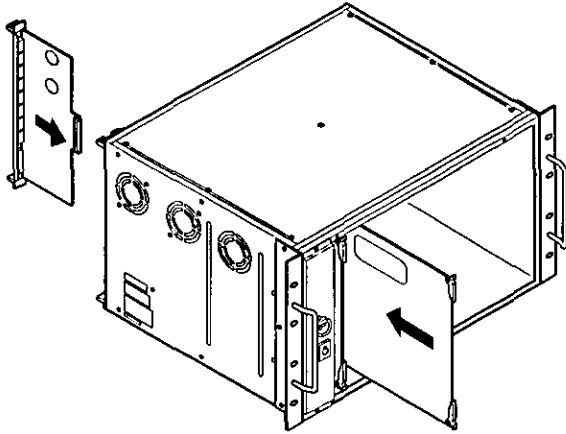

5. Make sure to push in the Boards until they are seated firmly.

6. Secure the rear board by tightening the two screws on the board.

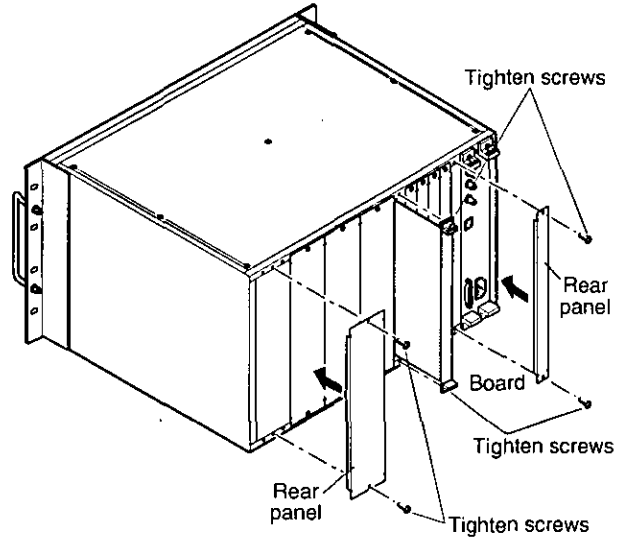

7. Close open spaces on the rear of the Cage with the supplied rear panel(s).

8. Close the front of the cage by fixing the front panel.

## ■ Specifications

Data Input/Output (1 - 8):	RS-485 [5-pin T(A), T(B), R(A), R(B), G) x8 Full Duplex or Half Duplex selectable
Transmission Speed (Baud Rate):	1 200 - 19 200 bps
Dimensions:	Front Board: 255(W) x 250(H) x 12(D) mm 10-1/16"(W) x 9-13/16"(H) x 1/2"(D) Rear Board: 117.5(W) x 265(H) x 20(D) mm 4-5/8"(W) x 10-7/16"(H) x 13/16"(D)
Weight:	0.5 kg (1.1 lbs)

Weight and dimensions indicated are approximate.  
Specifications are subject to change without notice.

**Panasonic Security and Digital Imaging Company**  
**A Division of Matsushita Electric Corporation of America**  
**Executive Office:** One Panasonic Way 3E-7, Secaucus, New Jersey 07094  
**Regional Offices:**  
 Northeast: One Panasonic Way, Secaucus, NJ 07094 (201) 348-7303  
 Southern: 1225 Northbrook Parkway, Suite 1-160, Suwanee, GA 30024 (770) 338-6838  
 Midwest: 1707 North Randall Road, Elgin, IL 60123 (847) 468-5211  
 Western: 6550 Katella Ave., Cypress, CA 90630 (714) 373-7840

**Panasonic Canada Inc.**  
 5770 Ambler Drive, Mississauga,  
 Ontario, L4W 2T3 Canada (905)624-5010

**Panasonic Sales Company**  
**Division of Matsushita Electric of Puerto Rico Inc.**  
 Ave. 65 de Infanteria, Km. 9.5  
 San Gabriel Industrial Park, Carolina,  
 Puerto Rico 00985 (809)750-4300